

IKA®

Pilots



Designed
to work perfectly

IKA® agitators

Reliable helpers get things moving at the pilot plant

RW 28 basic

For batches up to 80 ltr (H₂O)
Powerful, mechanically controlled stirrer.

Technical data

Motor power	220 W
Max. viscosity	50.000 mPa·s
Speed range* I	60 – 400 rpm
Speed range* II	240 – 1.400 rpm

Package including:

RW 28 basic (drive), R 271 Boss head clamp,
R 2723 Telescopic stand, R 1385 Propeller stirrer

Ident. No. 9019400

~~2.595,00~~ EUR

1.880,00 EUR



RW 47 D

For batches up to 200 ltr (H₂O). The most powerful
IKA® stirrer for laboratories, pilot plants and small-scale
production, with a three-phase motor.

Technical data

Motor power	513 W
Max. viscosity	100.000 mPa·s
Speed range* I	57 – 275 rpm
Speed range* II	275 – 1.300 rpm

Package including:

RW 47 D (drive), R 474 Telescopic stand
R 2302 Propeller stirrer

Ident. No. 9019500

~~4.157,00~~ EUR

3.045,00 EUR



Agitators IKA®-TURBOTRON® RKG-00-Bo

Agitators with the approval for use in Ex-Zone 1 (2G),
T3 acc. to the ATEX 95 directive.

RKG-00-Bo 0,25 kW ATEX

For batches up to 80 ltr (H₂O)

Technical data

Motor power	250 W
Max. viscosity	50.000 mPa·s
Speed range	20 – 1.200 rpm

Package including:

RKG-00-Bo 0,25 kW ATEX (drive),
R 271 Boss head clamp, R 2723-ATEX Telescopic stand,
R 1385 Propeller stirrer, adapter for fixing,
stirrer shaft protection

Ident. No. U098950

~~4.541,00~~ EUR

3.710,00 EUR



Ex-protected design

Agitator IKA®-TURBOTRON® RKG-00-Bo ATEX with 0,55 kW motor, suitable stand and accessories
Ident. No. U098955. Price: 3.870,00 EUR (instead of ~~4.947,00~~ EUR)

Magnetic stirrers series MR 1

Powerful magnetic stirrer without heating. Casing and
bottom plate made of stainless steel. Infinitely adjustable
speed. Magnetic stirring bar IKAFLO® 50 included.

Midi MR 1 digital IKAMAG®

For mixing volumes up to 50 ltr (H₂O)

Technical data

Speed range	0 – 1.000 rpm
Speed display	LCD
Timer	0 – 56 min
Base plate dimensions	350 x 350 mm

Ident. No. 2621900

1.890,00 EUR



Magnetic stirrer Maxi MR 1 digital (base plate dimensions 500 x 500 mm)
Ident. No. 2621800. Price: 2.610,00 EUR

IKA® batch dispersing machines

Efficient processes for every approach

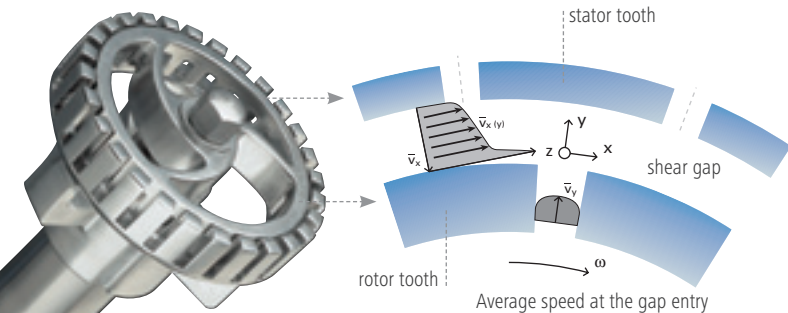

Due to the high rotational speed of the rotor, the medium to be processed is drawn axially into the dispersion head and then forced radially through the slots in the rotor/stator arrangement. The high accelerations acting on the material produce extremely strong shear and thrust forces. In addition, high turbulence occurs in the shear gap between rotor and stator, which provides optimum mixing of the suspension.

T 65 D ULTRA-TURRAX®

For volumes from 2 up to 50 ltr (H₂O)

Technical data

Motor power	1,8 kW
Max. viscosity	5.000 mPa·s
Shaft length	520 mm
Speed	7.200 rpm
Circumferential speed	21,9 m/s

Package including:

T 65 D (drive), T 653 Telescopic stand,
S 65 KG-HH-G 65 G Dispersing tool

Ident. No. 9019600

~~5.060,00~~ EUR

4.500,00 EUR



Batch dispersing machines IKA® ULTRA-TURRAX® UTC

UTC T 80/2-KT (w/o figure)

with integrated frequency converter
For batches from 25 up to 150 ltr (H₂O)

Technical data

Motor power	3 kW
Max. viscosity	5.000 mPa·s
Shaft length	650 mm
Speed range	1.200 – 5.200 rpm
Speed	5 – 17 m/s

Package including:

UTC 80-KT (drive), T 2 Dispersing tool
SFH 75 Mobile stand

Ident. No. U098963

6.320,00 EUR

~~7.020,00~~ EUR

UTC T 115/4-KT ATEX

For batches up to 500 ltr (H₂O).
Approval for use in Ex-Zone 1 (2G),
T3 acc. to the ATEX 95 directive.

Technical data

Motor power	3 kW
Max. viscosity	5.000 mPa·s
Shaft length	965 mm
Speed	3.000 rpm

Package including:

UTC 115-KT ATEX (drive), T 4 Dispersing tool,
SFH 150 Mobile stand

Ident. No. U098965

6.790,00 EUR

~~7.540,00~~ EUR

On request extension of the delivery
with electric control.



IKA® inline dispersing machines

Ideal results, non-stop

IKA® magic LAB® 2000/03

Small laboratory inline dispersing machine for the production of emulsions and suspensions. Incl. control and info center, temperature sensor PT 100, transport box with telescopic handle and integrated mains unit.



Technical data

Motor power	900 W
Adjustable speed range	3.000 - 26.000 rpm
Circumferential speed at standard speed 16.000 rpm	23 m/s
Flow capacity at standard speed	130 ltr/h (H ₂ O)

Basic version with module UTL

Ident. No. U078310

5.450,00 EUR

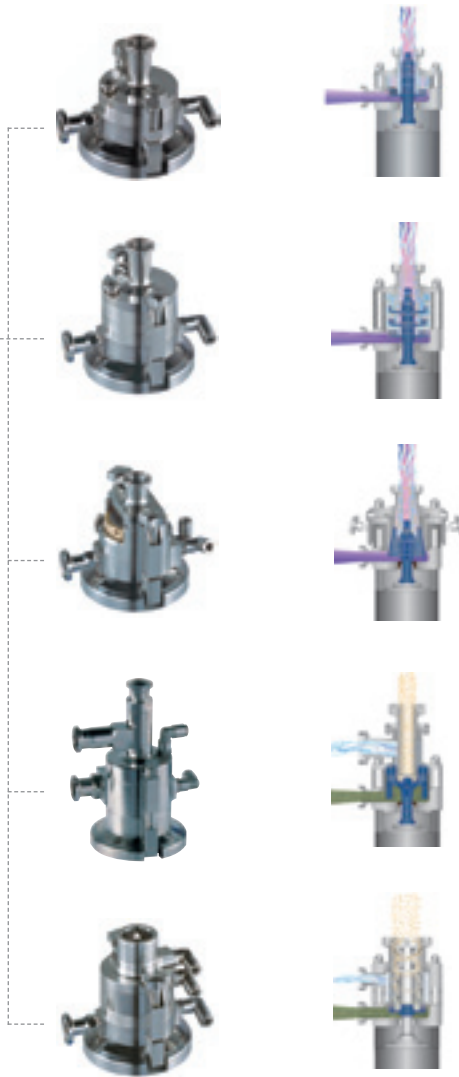

Module ULTRA-TURRAX® UTL

For manufacturing of coarse emulsions and suspensions
Flow rate: approx. 130 ltr/h (H₂O)
Included with delivery.

Module DISPAX-REACTOR® DR

For manufacturing of fine emulsions and suspensions
Flow rate: approx. 80 ltr/h (H₂O)
Ident. No. U078352

880,00 EUR

Module Colloid mill MK / Cone mill MKO

For wet-milling
Flow rate (MK/MKO): approx. 200 ltr/h / approx. 25 ltr/h (H₂O)
Ident. No. (MK/MKO): U076662 / U079664

1.980,00 EUR

Module CMS

Solid-liquid-mixing in the recirculation process
Flow rate: approx. 1.000 ltr/h (H₂O)
Ident. No. U075333

1.760,00 EUR

Module MHD

Continuous solid-liquid-mixing
Flow rate: approx. 60 ltr/h (H₂O)
Ident. No. U075262

1.540,00 EUR

One machine for many mixing tasks.

Same working modules for laboratory and production!

IKA® magic LAB® Mounting examples



magic LAB® with module CMS and accessories for powder incorporation into liquid in recirculation mode



magic LAB® for batch process as ULTRA-TURRAX®



magic LAB® with module Micro-Plant 1 ltr for recirculation process in the open vessel



magic LAB® with module Micro-Plant 2 ltr for recirculation process in the closed vessel

IKA® LABOR-PILOT 2000/04

Inline dispersing machine in pilot size with upscale possibilities on the production scale. Standard execution with module UTL.

Recommended accessory: LABOR-PILOT-CONTROLLER

Optional: Exchangeable working modules

Technical data

Motor power	1,5 kW
Speed	8.050 rpm
Circumferential speed	9,4 – 41 m/s
Flow capacity (UTL)	ca. 500 ltr/h (H ₂ O)

Ident. No. T055396

4.230,00 EUR

LABOR-PILOT-CONTROLLER

Ident. No. T055171 / Price: 3.160,00 EUR



IKA® PROCESS-PILOT 2000/04

Inline dispersing machine in pilot size, similar to LABOR-PILOT, but:

- with more powerful motor
- equipped with double mechanical seal
- for operation under vacuum / pressure (10 bar)
- for working at elevated temperatures

Technical data

Motor power	2,2 kW
Speed	8.050 rpm
Circumferential speed	9,4 – 41 m/s
Flow capacity (UTL)	ca. 500 ltr/h (H ₂ O)

Ident. No. T058102

8.890,00 EUR

PROCESS-PILOT-CONTROLLER

Ident. No. T058761 / Price: 3.300,00 EUR



Available also in
Ex-protected design

High pressure homogenizer HPH 2000/04

Particle and droplet size reduction to the nano range. Versions with one (SH) or two (DH) pistons with correspondingly different capacity are available. Execution acc. to GMP as well as CIP or SIP capability on request.

HPH 2000/4-SH5

Technical data

Motor power	1,5 kW
Homogenizing pressure max.	2.000 bar
Min. feeding volume	10 mltr
No. of pistons	1
Flow rate (H ₂ O)	3 ltr/h

Ident. No. U068906

11.100,00 EUR

HPH-CONTROLLER

Frequency range: 20 – 50 Hz

Ident. No. U071728 / Price: 3.160,00 EUR



HPH 2000/4-DH5

Technical data

Motor power	1,5 kW
Homogenizing pressure max.	2.000 bar
Min. feeding volume	20 mltr
No. of pistons	2
Flow rate (H ₂ O)	6 ltr/h

Ident. No. U071735

13.800,00 EUR

HPH-CONTROLLER

Frequency range: 20 – 50 Hz

Ident. No. U071728 / Price: 3.160,00 EUR



Master Plant MP 10

Ideal and compact laboratory and pilot plant for mixing and dispersing in batch. Highest product quality and an extreme reduction of the output time. Special Ex-proof version of the system MP 10 on request.

Technical data

Useful volume	1,5 - 10 ltr
Process temperature	-10 up to 150°C
Vacuum /pressure	10 mbar / 2,5 bar
Max. viscosity	100.000 mPa·s
Frequency range	20-60 Hz
Speed range agitator	48 - 144 rpm
Speed range disperser	3.160 – 9.480 rpm
Max. flow capacity of DBI during dispersing	2.000 ltr/h

MP 10, version 1

Vessel with discharge valve, lifting device, spiral agitator

Ident. No. U098988

25.810,00 EUR

MP 10, version 2

Vessel, lifting device, spiral agitator, dispersing machine DBI, circulation loop, 1 feeding funnel, controller

Ident. No. U084530

50.330,00 EUR



Laboratory reactor LR 2.ST

Modular design laboratory reactor for optimization and simulation of various chemical reactions as well as for mixing and homogenizing processes in a laboratory scale.

LR 2.ST consisting of: Stand system, stirrer, anchor stirrer, safety shutdown and reactor cover. Many extension capabilities are optionally available.



Technical data

Useful volume	0,5 - 2 ltr
Max. process temperature	230°C
Admissible vacuum	25 mbar
Max. viscosity	150.000 mPa·s
Speed range	8 - 290 rpm



Package 1

LR-2.ST with single walled reactor vessel LR 2.1

Ident. No. 9008400

8.300,00 EUR



Package 2

LR-2.ST with double walled reactor vessel LR 2000.1

Ident. No. 9008500

8.900,00 EUR



Package 3

LR-2.ST with double walled reactor vessel LR 2000.2, incl. bottom discharge valve

Ident. No. 9008600

9.400,00 EUR

Validity of prices

The prices in this brochure are recommended prices only. We reserve the right to replace these prices by new, subsequent ones as a response to changing circumstances; this right also applies if the printed price is a blatantly obvious printing error. All prices exclusive of VAT. Prices are subject to change. Prices valid until 12.31.2010. Subject to technical changes.

IKA®-Werke GmbH & Co KG

Janke & Kunkel-Str. 10

79219 Staufen · Germany

Tel.: +49 7633 831-0 · Fax: +49 7633 831-98

E-Mail: sales@ika.de · www.ika.com



Designed
to work perfectly